

METAL EARTH™

3D LASER CUT MODELS

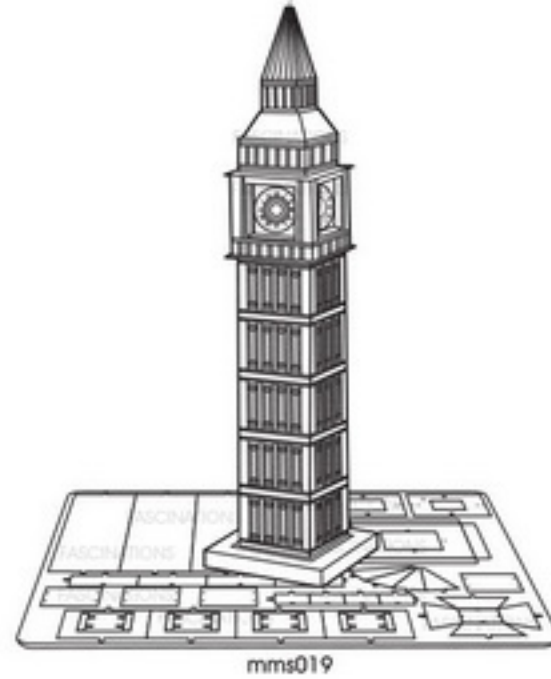

It is highly recommended that you visit
www.fascinations.com/metalearth360/mms019
 to see the completed model before assembling your own



mms019

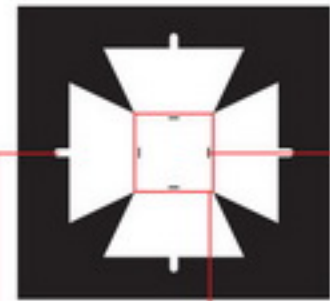

Insertion tabs are inserted and then folded
 Fold lines can be seen as shown here
 Insertion holes

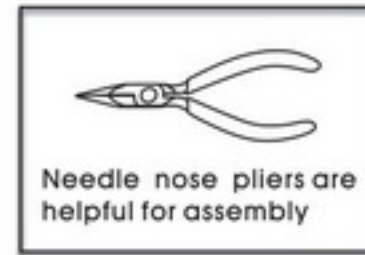

Metal sheet

To create the best connections

Insert tab and bend 90 degrees for most visible areas

Insert tab and twist 90 degrees is best in some areas to ensure a tight connection

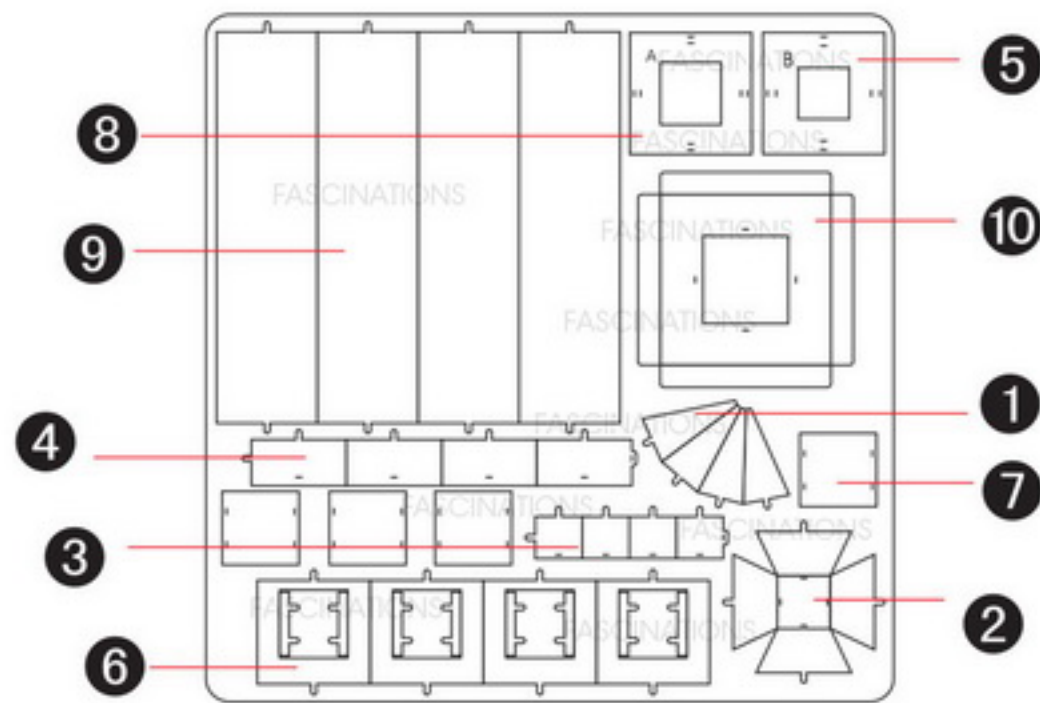
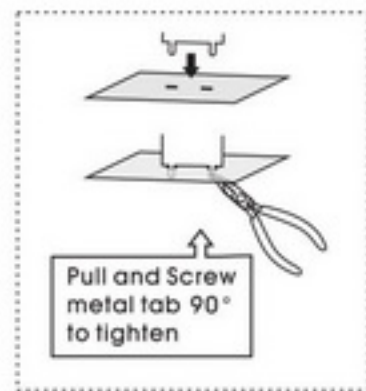

Assembly Flow Chart

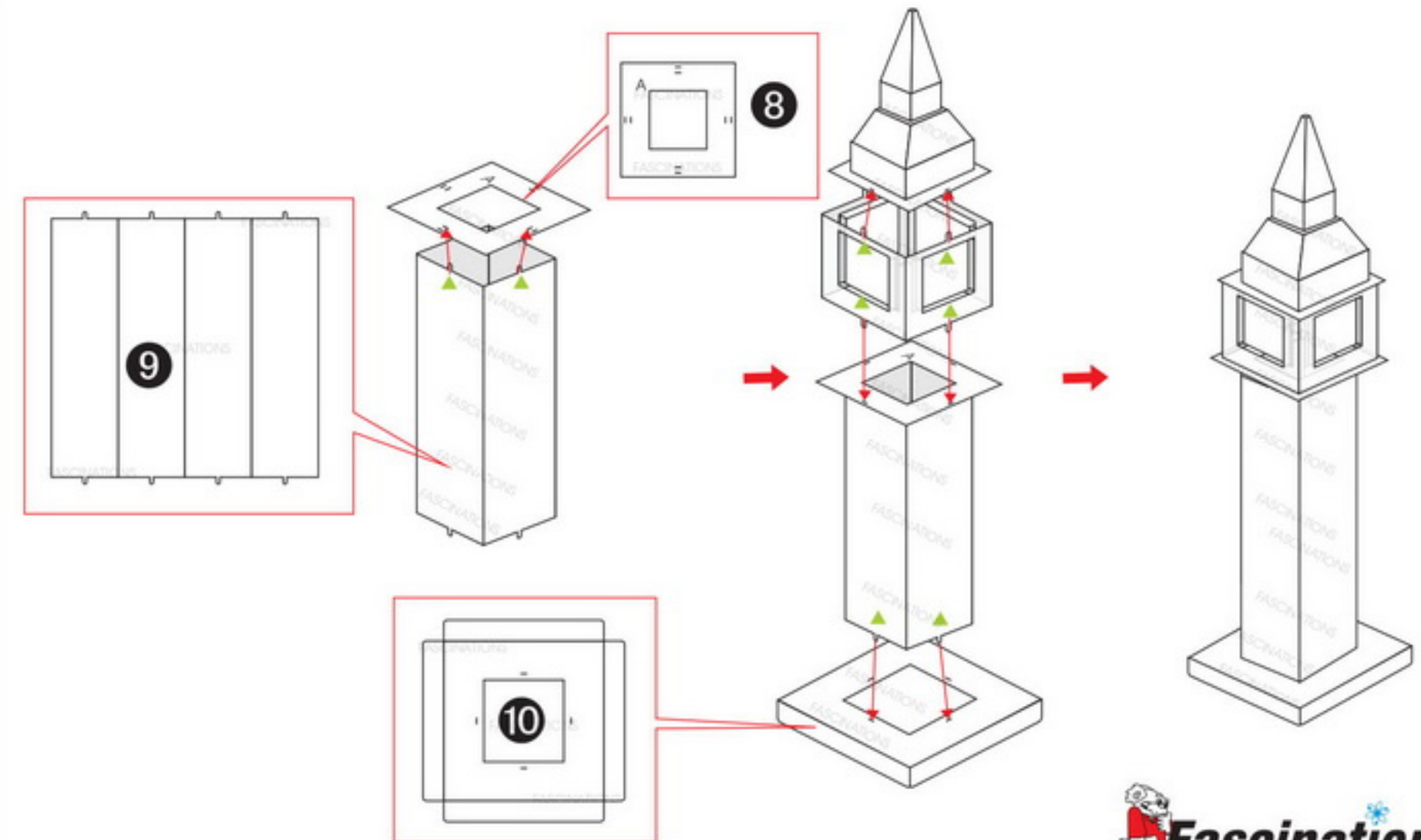
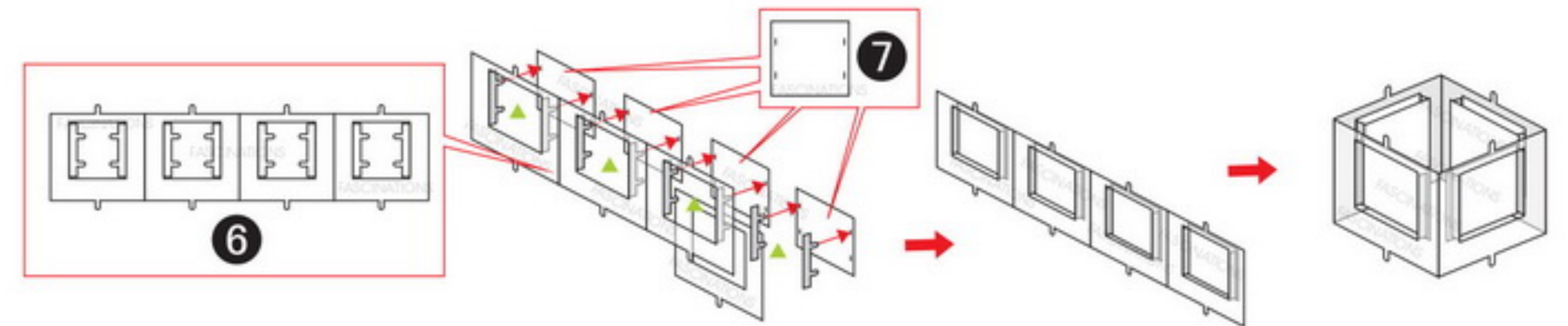
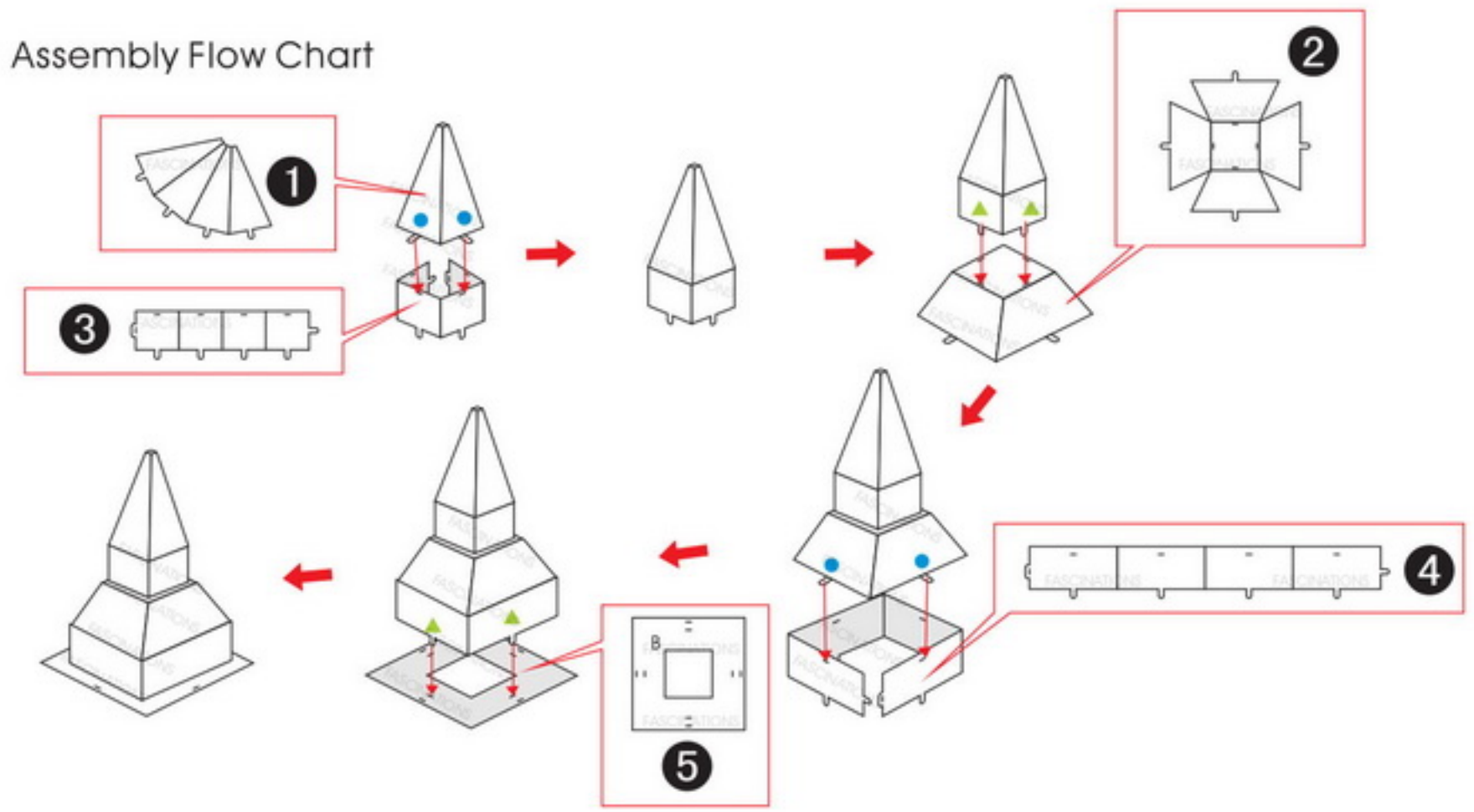

In order to avoid possible injury from sharp edges, please carefully discard the metal sheet after parts have been removed